

SB SERIES

180° BULLNOSES

SAMPLE SPECIFICATION

specify as: SOFTFORMS® Model # SB-XXX-X

Pittcon SOFTFORMS® LLC

6409 Rhode Island Avenue
Riverdale, MD 20737
(800) 637-7638
(301) 927-1000
Fax: (301) 699-8690

3330 W. Flower Street
Phoenix, AZ 85017
(800) 637-7638
(602) 233-9100
Fax: (602) 233-9400

The extruded aluminum profile shall incorporate a continuous integral fin for surface contact to conventionally installed gypsum drywall. The fins shall be 7/8" wide and shall be tapered to the edge. The tapered fins shall be punched with holes staggered to accept standard screw fastening. A series of continuous grooves shall be extruded into the face of the fins to provide greater bonding surface. The extruded profiles shall be primed with corrosion-resistant primer compatible with materials normally in use in conjunction with commercial interiors, i.e.: joint compound, latex and enamel paints, and wall covering adhesives.

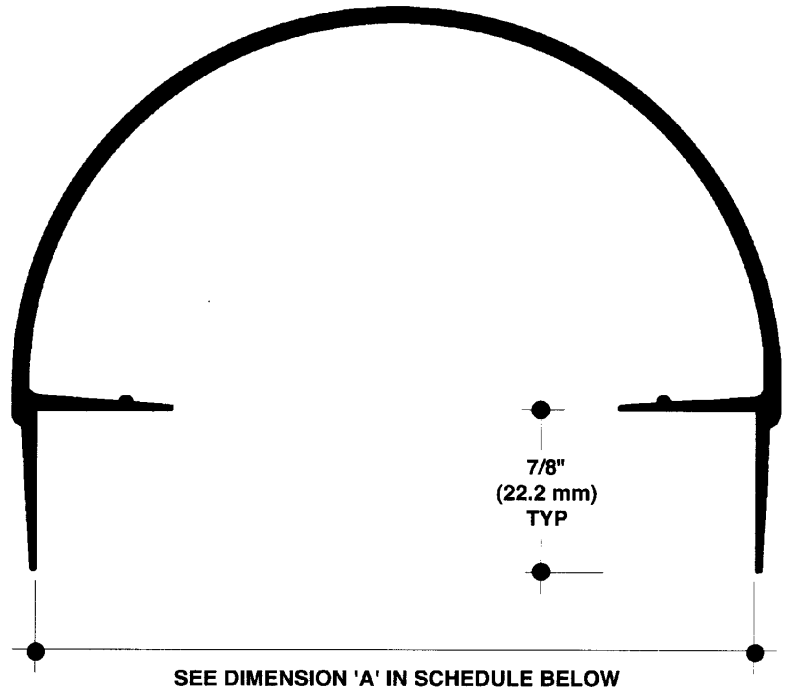

MATERIAL: Aluminum alloy.....6063 T5 or equal
Finish.....Factory primed

SB-212-8
NO SCALE

BULLNOSE
SECTION

SELECTING YOUR SOFTFORMS® SB SERIES OF ALUMINUM EXTRUSIONS

Select proper SOFTFORMS® extrusion from the ordering information shown below.

Model No.	Stud Size	Type of GPDW	Dim 'A' Width
SB-158-8	1-5/8" (41.3mm)	5/8" (15.9mm)	3" (76.2mm)
SB-212-2	2-1/2" (63.5mm)	1/2" (12.7mm)	3-5/8" (92.01mm)
SB-212-8	2-1/2" (63.5mm)	5/8" (15.9mm)	3-7/8" (98.4mm)
SB-358-2	3-5/8" (92.2mm)	1/2" (12.7mm)	4-3/4" (120.6mm)
SB-358-8	3-5/8" (92.2mm)	5/8" (15.9mm)	5" (127mm)
SB-400-8	4" (101.6mm)	5/8" (15.9mm)	5-3/8" (136.5mm)
SB-600-8	6" (152.4mm)	5/8" (15.9mm)	7-3/8" (187mm)

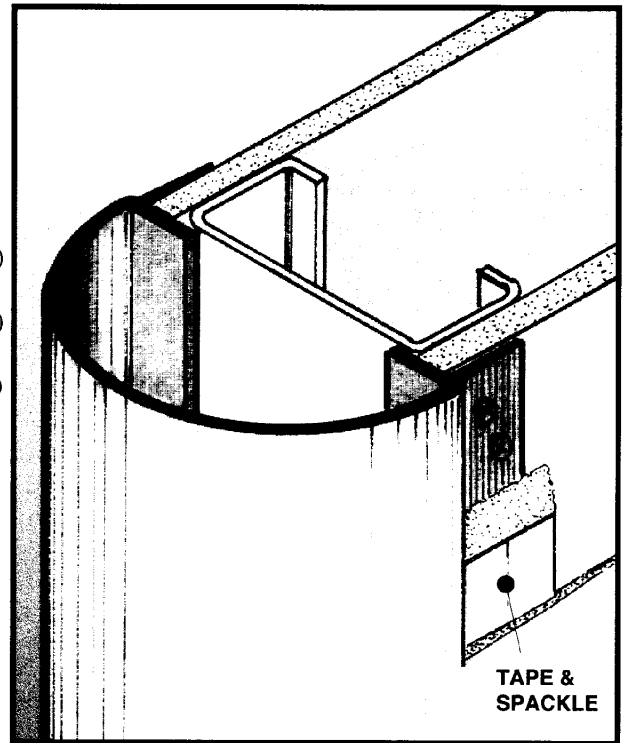

All details, methods and specifications are the exclusive property of Pittcon Softforms® LLC. Pittcon reserves the right to change any specifications or details without prior notification. All Softforms® profiles are available in standard 10' lengths ±1/8" (2.048 M). Other lengths are available as special order items. For custom shapes, sizes, or for special finishes, please contact the factory or your nearest Pittcon sales representative.

SB SERIES

180° BULLNOSES

SAMPLE SPECIFICATION

specify as: SOFTFORMS®

Model # SB-XXX-X

SELECTING YOUR SOFTFORMS® SB SERIES OF ALUMINUM EXTRUSIONS

Select proper SOFTFORMS® extrusion from the ordering information shown below.

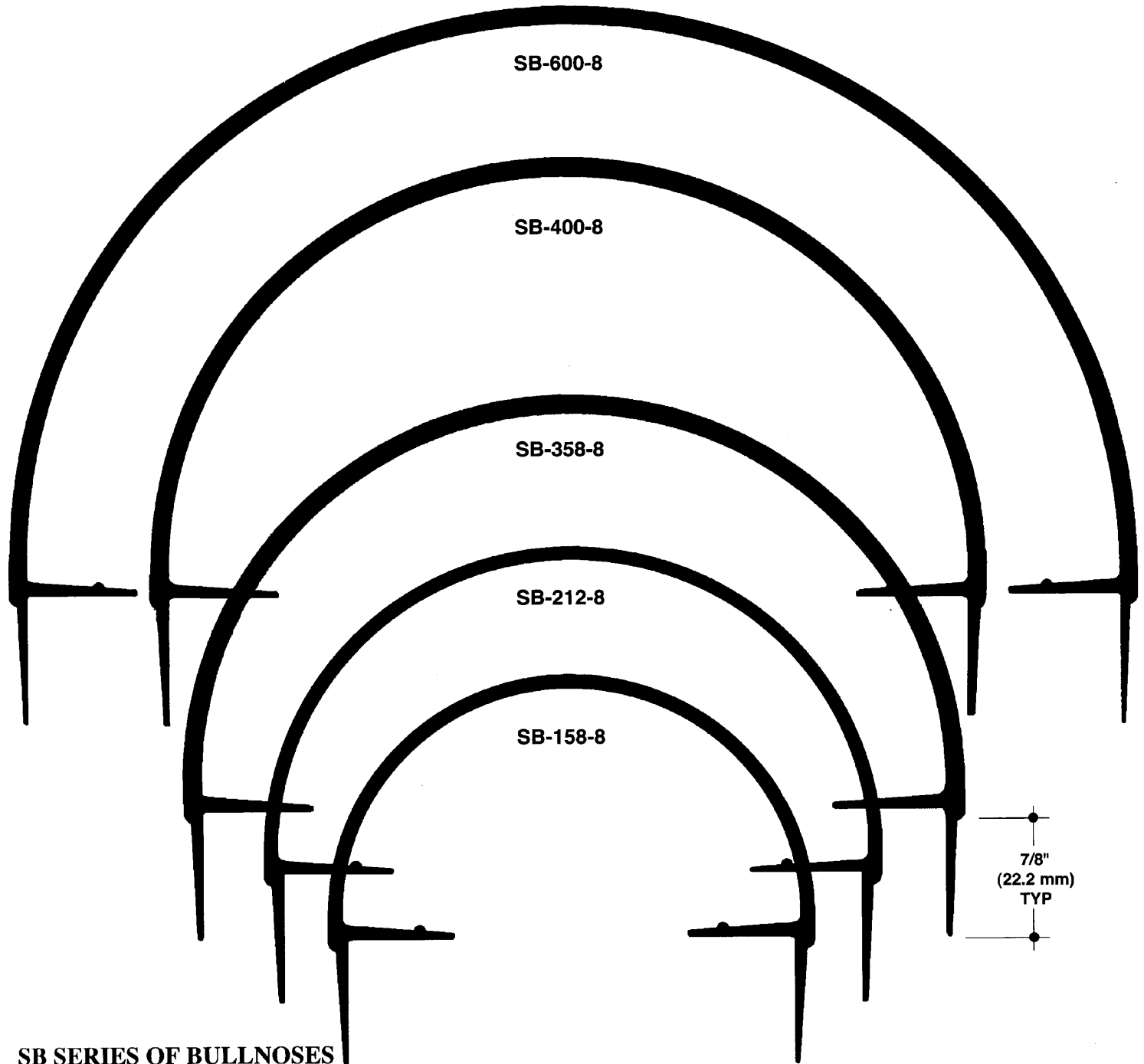

SB SERIES OF BULLNOSES

NO SCALE

Pittcon SOFTFORMS® LLC

6409 Rhode Island Avenue
Riverdale, MD 20737
(800) 637-7638
(301) 927-1000
Fax: (301) 699-8690

3330 W. Flower Street
Phoenix, AZ 85017
(800) 637-7638
(602) 233-9100
Fax: (602) 233-9400

Softforms®

PREFORMED ARCHITECTURAL PROFILES
FOR DRYWALL CONSTRUCTION

SSB-212-8 SNAP-ON BULLNOSE

SAMPLE SPECIFICATION

specify as: SOFTFORMS®

Model # SSB-212-8
Model # SC-212-XXX

Pittcon SOFTFORMS® LLC

6409 Rhode Island Avenue
Riverdale, MD 20737
(800) 637-7638
(301) 927-1000
Fax: (301) 699-8690

3330 W. Flower Street
Phoenix, AZ 85017
(800) 637-7638
(602) 233-9100
Fax: (602) 233-9400

The extruded aluminum profiles shall be 1/8" thick at the exposed portion and shall incorporate a continuous integral grooved angle to mate with the SC-212-800, SC-212-825, SC-212-850, or SC-212-875 extended clip mount.

MATERIAL: Aluminum alloy.....6063 T5 or equal
Finish.....Mill Finish

Optional factory applied finishes are available. Please check with factory for pricing and availability of your desired finish.

EXAMPLE DETAIL

For use with 2-1/2" metal stud construction and 5/8" GPDW. The SSB-212-8 works as a wall termination (where a reveal is desired) for vertical and horizontal wall applications with standard metal or wood stud construction.

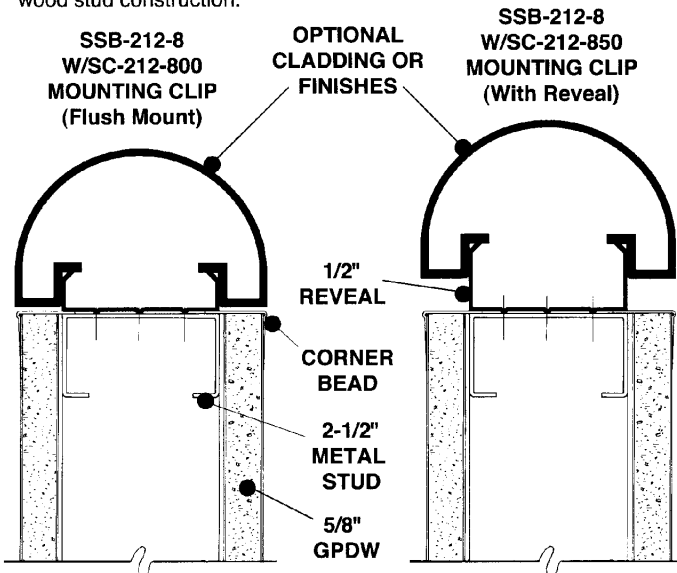

SSB-212-8 @ 2-1/2" PARTITION END
NO SCALE PLAN/SECTION

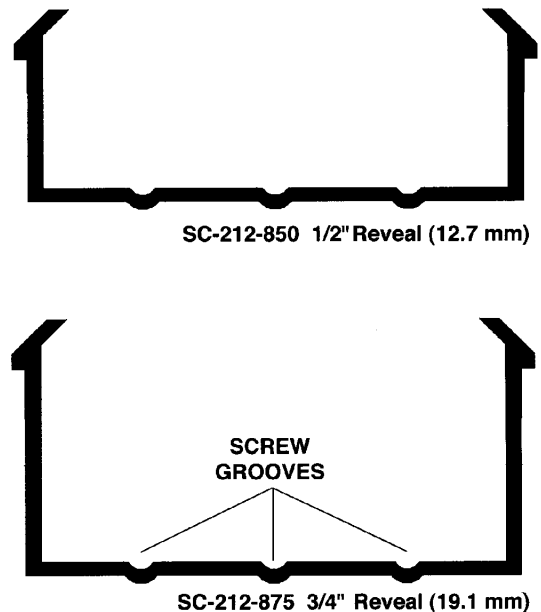
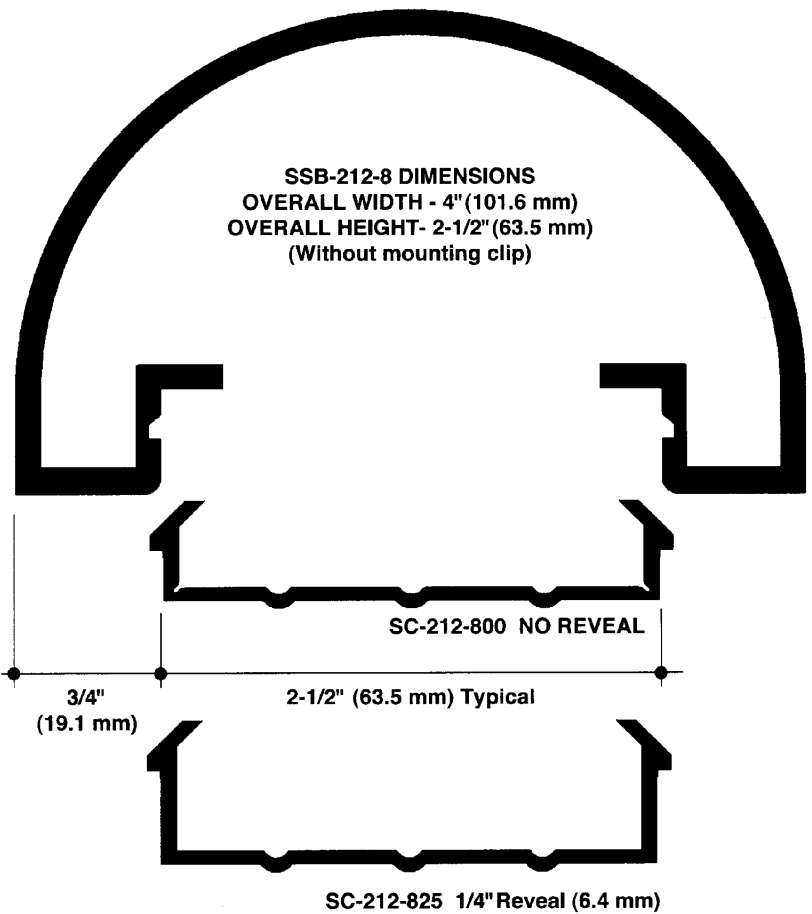

SSB-212-8 SNAP-ON BULLNOSE W/CLIP MOUNTS
NO SCALE SECTIONS

All details, methods and specifications are the exclusive property of Pittcon Softforms® LLC. Pittcon reserves the right to change any specifications or details without prior notification. All Softforms® profiles are available in standard 10' lengths ±1/8" (2.048 M). Other lengths are available as special order items. For custom shapes, sizes, or for special finishes, please contact the factory or your nearest Pittcon sales representative.

SSB-358-8

SNAP-ON BULLNOSE

SAMPLE SPECIFICATION

specify as: SOFTFORMS®

Model # SSB-358-8

Model # SC-358-XXX

Pittcon SOFTFORMS® LLC

6409 Rhode Island Avenue
Riverdale, MD 20737
(800) 637-7638
(301) 927-1000
Fax: (301) 699-8690

3330 W. Flower Street
Phoenix, AZ 85017
(800) 637-7638
(602) 233-9100
Fax: (602) 233-9400

The extruded aluminum profiles shall be 1/8" thick at the exposed portion and shall incorporate a continuous integral grooved angle to mate with the SC-358-800, SC-358-825, SC-358-850, or SC-358-875 extended clip mount.

MATERIAL: Aluminum alloy.....6063 T5 or equal
Finish.....Mill Finish

Optional factory applied finishes are available. Please check with factory for pricing and availability of your desired finish.

EXAMPLE DETAIL

For use with 3-5/8" metal stud construction and 5/8" GPDW. The SSB-358-8 works as a wall termination (where a reveal is desired) for vertical and horizontal wall applications with standard metal or wood stud construction.

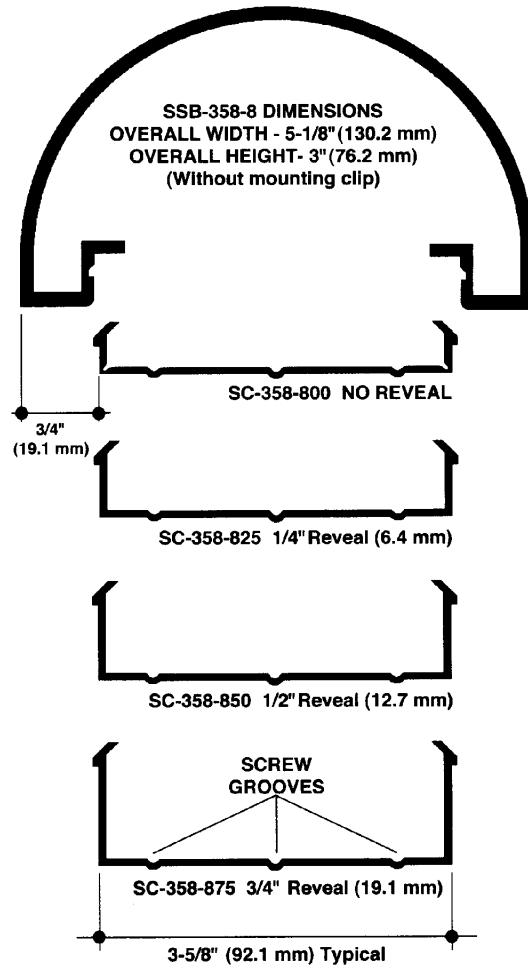
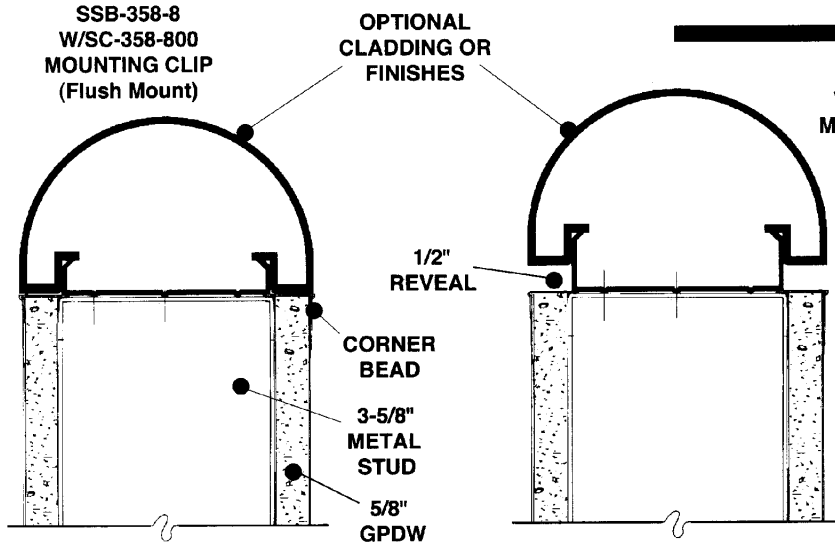

SSB-358-8 SNAP-ON BULLNOSE W/CLIP MOUNTS

NO SCALE SECTIONS

SSB-358-8
W/SC-358-850
MOUNTING CLIP
(With Reveal)

SSB-358-8 @ 3-5/8" PARTITION END

NO SCALE

PLAN/SECTION

All details, methods and specifications are the exclusive property of Pittcon Softforms® LLC. Pittcon reserves the right to change any specifications or details without prior notification. All Softforms® profiles are available in standard 10' lengths ±1/8" (2.048 M). Other lengths are available as special order items. For custom shapes, sizes, or for special finishes, please contact the factory or your nearest Pittcon sales representative.

Softforms®

PREFORMED ARCHITECTURAL PROFILES
FOR DRYWALL CONSTRUCTION

SO 58

SSB-600-8 SNAP-ON BULLNOSE

SAMPLE SPECIFICATION

specify as: SOFTFORMS®

Model # SSB-600-8

Model # SC-600-850

Pittcon SOFTFORMS® LLC

6409 Rhode Island Avenue
Riverdale, MD 20737
(800) 637-7638
(301) 927-1000
Fax: (301) 699-8690

3330 W. Flower Street
Phoenix, AZ 85017
(800) 637-7638
(602) 233-9100
Fax: (602) 233-9400

The extruded aluminum profiles shall be 1/8" thick at the exposed portion and shall incorporate a continuous integral grooved angle to mate with the SC-600-850 extended clip mount.

MATERIAL: Aluminum alloy.....6063 T5 or equal
Finish.....Mill Finish

Optional factory applied finishes are available. Please check with factory for pricing and availability of your desired finish.

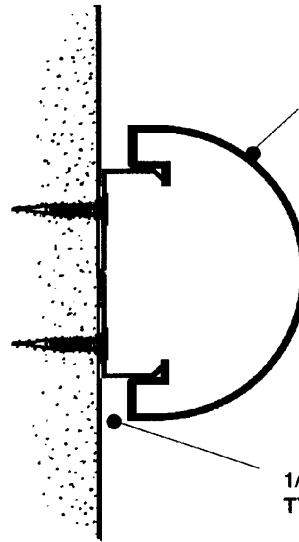

OPTIONAL CLADDING
OR FINISHES

NOTE:
SCREWS MUST ALWAYS
ENGAGE METAL OR
WOOD SUBSTRUCTURE
TO ENSURE PROPER
INSTALLATION

1/2" REVEAL
TYPICAL

SSB-600-8 and SC-600-850 Clip Decorative Bullnose
NO SCALE SECTION

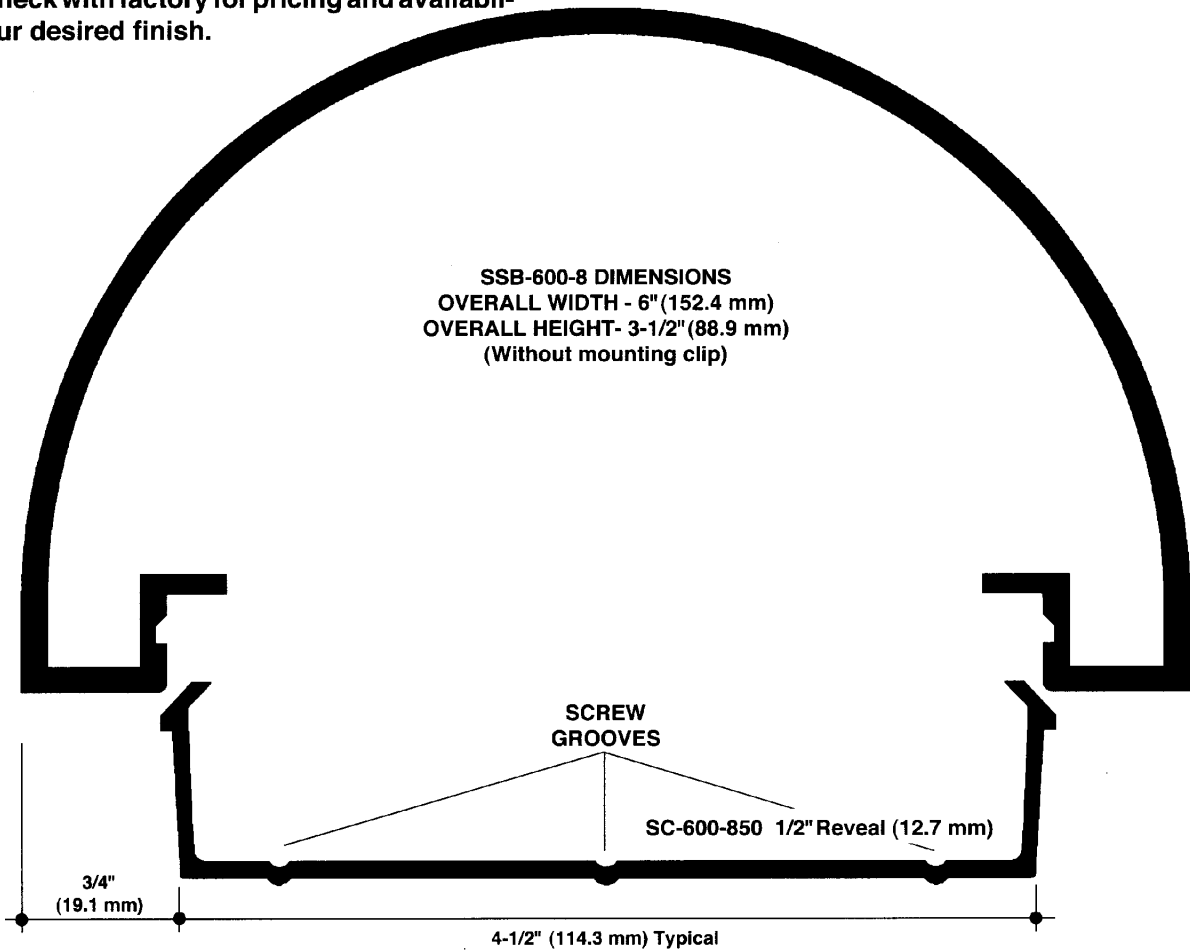

SSB-600-8 DIMENSIONS
OVERALL WIDTH - 6" (152.4 mm)
OVERALL HEIGHT - 3-1/2" (88.9 mm)
(Without mounting clip)

SCREW
GROOVES

SC-600-850 1/2" Reveal (12.7 mm)

3/4"
(19.1 mm)

4-1/2" (114.3 mm) Typical

SSB-600-8 SNAP-ON BULLNOSE

W/ SC-600-850 CLIP MOUNT

NO SCALE

SECTION

All details, methods and specifications are the exclusive property of Pittcon Softforms® LLC. Pittcon reserves the right to change any specifications or details without prior notification. All Softforms® profiles are available in standard 10' lengths ±1/8" (2.048 M). Other lengths are available as special order items. For custom shapes, sizes, or for special finishes, please contact the factory or your nearest Pittcon sales representative.

STB SERIES

180° BULLNOSES

SAMPLE SPECIFICATION

specify as: SOFTFORMS® Model # STB-XXX
 Model # SC-XXX (Clip)

Pittcon SOFTFORMS® LLC

6409 Rhode Island Avenue 3330 W. Flower Street
 Riverdale, MD 20737 Phoenix, AZ 85017
 (800) 637-7638 (800) 637-7638
 (301) 927-1000 (602) 233-9100
 Fax: (301) 699-8690 Fax: (602) 233-9400

The extruded aluminum profile shall be a nominal thickness of .050" at the exposed portion and shall incorporate a continuous integral angle to mate with extended mounting clip.

MATERIAL: Aluminum alloy.....6063 T5 or equal
 Finish.....Below

The STB Decorative Bullnose is available in a wide variety of finishes. These include satin or bright dipped anodized, as well as buffed or brushed finishes. See listing below for color and finish number. Please check with factory for pricing and availability of your desired finish.

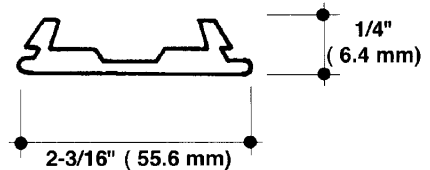
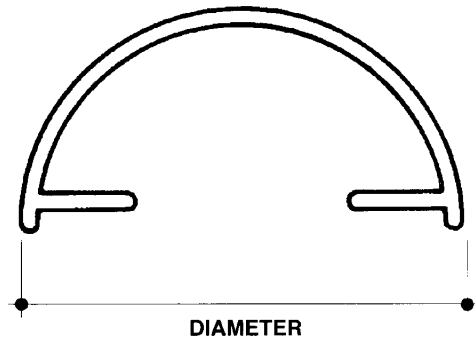

STB-202 and SC-540 CLIP Decorative Bullnose
 NO SCALE SECTION

SELECTING YOUR STB SERIES OF DECORATIVE ALUMINUM EXTRUSIONS

Select proper extrusion from the ordering information shown below.

STB Model Number	Diameter	Base Number	End Cap Number
STB-267 *	3/4" (19.1mm)	SC-526	N/A
STB-328 *	1" (25.4mm)	SC-526	EC-323
STB-200 *	1-1/2" (38.1mm)	SC-443	EC-204
STB-201 *	2" (50.8 mm)	SC-443	EC-205
STB-202 *	3" (76.2 mm)	SC-540	EC-206
STB-210 *	4" (101.6 mm)	SC-458	EC-207
STB-285 *	4-1/2" (114.3 mm)	SC-458	EC-238
STB-211 *	5" (127 mm)	SC-002	EC-208
STB-212 *	6" (152.4 mm)	SC-509	EC-209

* Limited availability on these sizes.

The STB SERIES of decorative bullnoses works as a wall accent trim where a complementary colored trim is needed to offset or terminate changes in wall colors. Available colors include natural, black, brass, bronze, brown, copper, pewter, stainless steel, and white gold. Check with factory for availability and lead time.

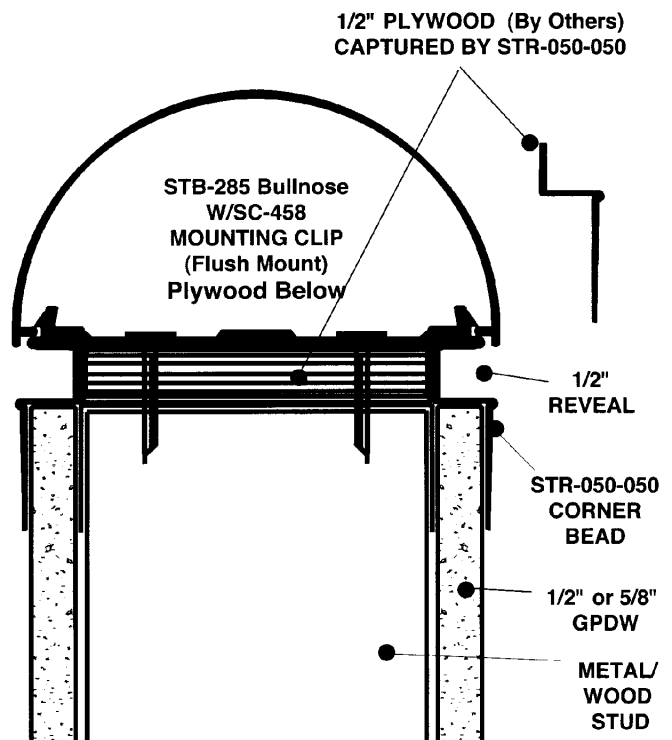

All details, methods and specifications are the exclusive property of Pittcon Softforms® LLC. Pittcon reserves the right to change any specifications or details without prior notification. All Softforms® profiles are available in standard 10' lengths ±1/8" (2.048 M). Other lengths are available as special order items. For custom shapes, sizes, or for special finishes, please contact the factory or your nearest Pittcon sales representative.

STB SERIES

180° BULLNOSES

SAMPLE SPECIFICATION

specify as: SOFTFORMS®

Model # STB-XXX

Model # SC-XXX (Clip)

SELECTING YOUR STB SERIES OF ALUMINUM EXTRUSIONS

Select proper extrusion from the ordering information shown below.

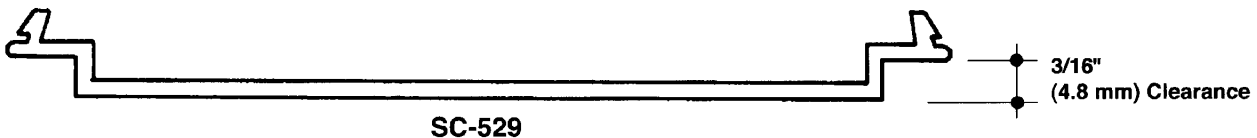
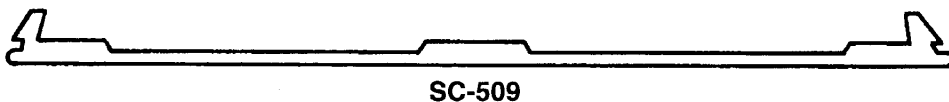
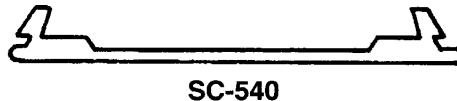
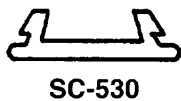
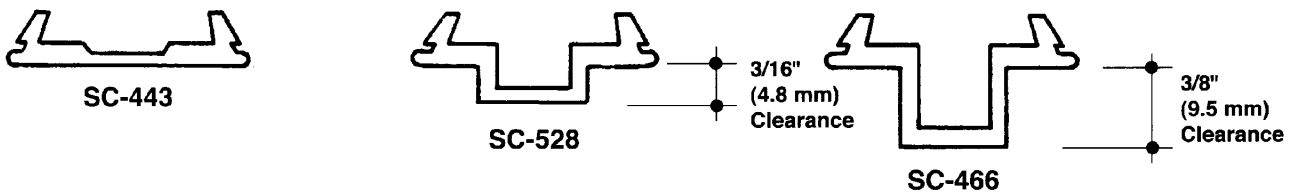
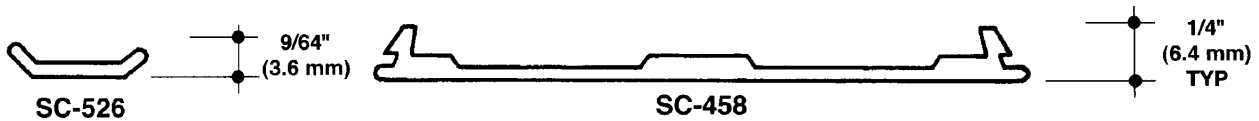

SC SERIES OF BULLNOSE MOUNTING CLIPS

NO SCALE

Pitcon SOFTFORMS® LLC

6409 Rhode Island Avenue
Riverdale, MD 20737
(800) 637-7638
(301) 927-1000
Fax: (301) 699-8690

3330 W. Flower Street
Phoenix, AZ 85017
(800) 637-7638
(602) 233-9100
Fax: (602) 233-9400

Softforms®
PREFORMED ARCHITECTURAL PROFILES
FOR DRYWALL CONSTRUCTION

SB-LDP

CUSTOM BULLNOSE

SAMPLE SPECIFICATION

specify as: SOFTFORMS® Model # SB-LDP

Pittcon SOFTFORMS® LLC

6409 Rhode Island Avenue	3330 W. Flower Street
Riverdale, MD 20737	Phoenix, AZ 85017
(800) 637-7638	(800) 637-7638
(301) 927-1000	(602) 233-9100
Fax: (301) 699-8690	Fax: (602) 233-9400

The formed aluminum profile shall incorporate a continuous integral fin for surface contact to conventionally installed gypsum drywall. The swedged fins shall be 1-3/8" wide nominally, with a raised shoulder for taping and spackling to. The formed profile shall be primed with a corrosion-resistant primer compatible with materials normally in use in conjunction with commercial interiors, i.e.: joint compound, latex and enamel paints, and wall covering adhesives. Screws through the installation fins must always engage wood or metal substructure in order to ensure proper installation.

MATERIAL: Aluminum alloy.....3003 H-14 or equal
 Finish.....Factory primed
 Thickness......090" Typical

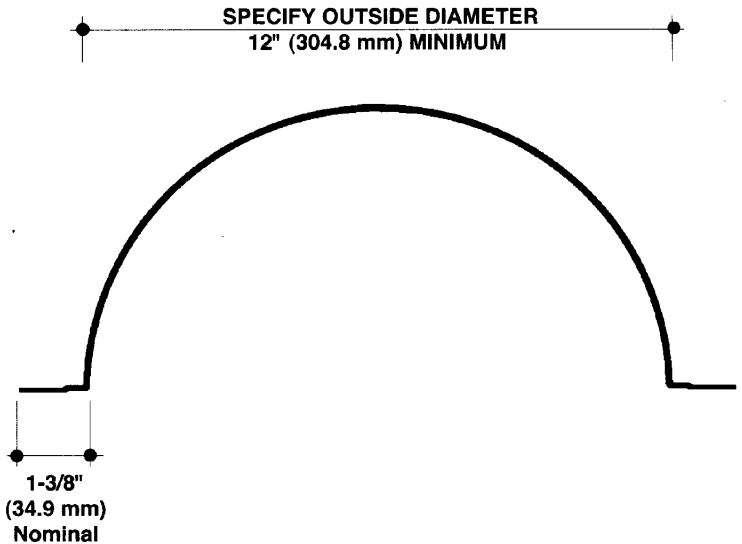

SB-LDP **CUSTOM BULLNOSE**
NO SCALE **SECTION**

EXAMPLE DETAIL

For use with conventional metal stud construction and 1/2" or 5/8" GPDW.

The SB-LDP is a large diameter bullnose or column cover with two perpendicular fins for drywall constructions similar to that depicted here. Screws through the installation fins must always engage metal or wood substructure to ensure proper installation.

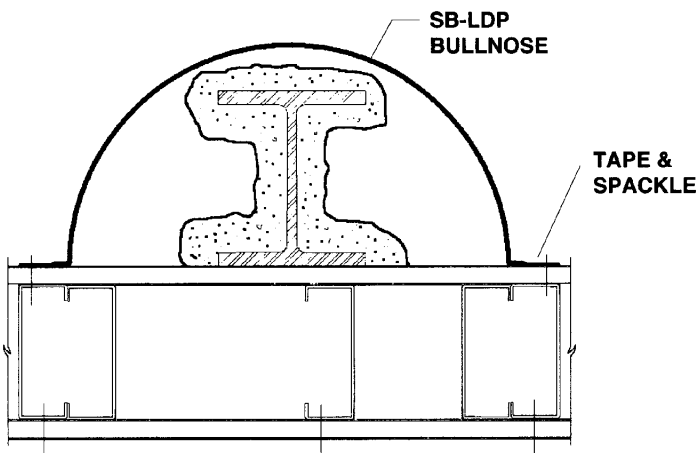

SB-LDP COLUMN COVER @ STUD WALL
NO SCALE **PLAN/SECTION**

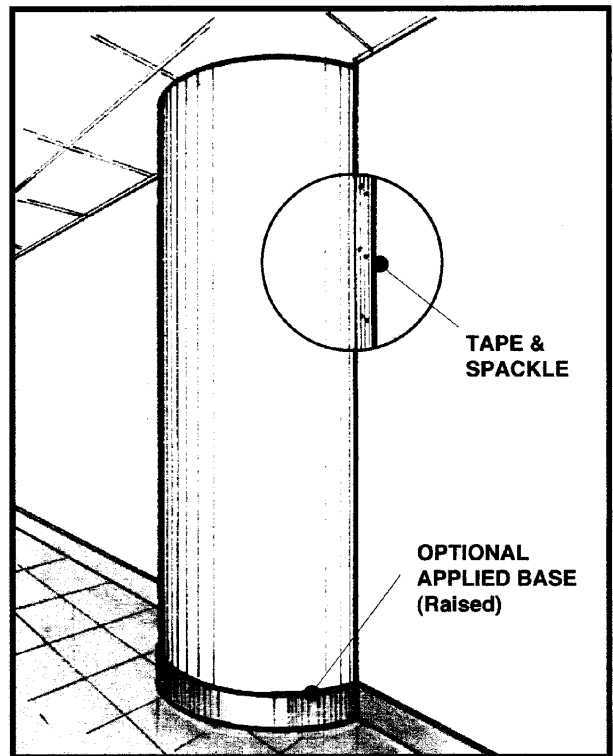

NOTE: REFER ALSO TO SERIES 100 COLUMN COVER BROCHURE

All details, methods and specifications are the exclusive property of Pittcon Softforms® LLC. Pittcon reserves the right to change any specifications or details without prior notification. All Softforms® profiles are available in standard 10' lengths ±1/8" (2.048 M). Other lengths are available as special order items. For custom shapes, sizes, or for special finishes, please contact the factory or your nearest Pittcon sales representative.

SB-LDT

CUSTOM BULLNOSE

SAMPLE SPECIFICATION

specify as: SOFTFORMS® Model # SB-LDT

Pittcon SOFTFORMS® LLC

6409 Rhode Island Avenue	3330 W. Flower Street
Riverdale, MD 20737	Phoenix, AZ 85017
(800) 637-7638	(800) 637-7638
(301) 927-1000	(602) 233-9100
Fax: (301) 699-8690	Fax: (602) 233-9400

The formed aluminum profile shall incorporate a continuous integral fin for surface contact to conventionally installed gypsum drywall. The swedged fins shall be 1-3/8" wide nominally, with a raised shoulder for taping and spackling to. The formed profile shall be primed with a corrosion-resistant primer compatible with materials normally in use in conjunction with commercial interiors, i.e.: joint compound, latex and enamel paints, and wall covering adhesives. Screws through the installation fins must always engage wood or metal substructure in order to ensure proper installation.

MATERIAL: Aluminum alloy.....3003 H-14 or equal
 Finish.....Factory primed
 Thickness......090" Typical

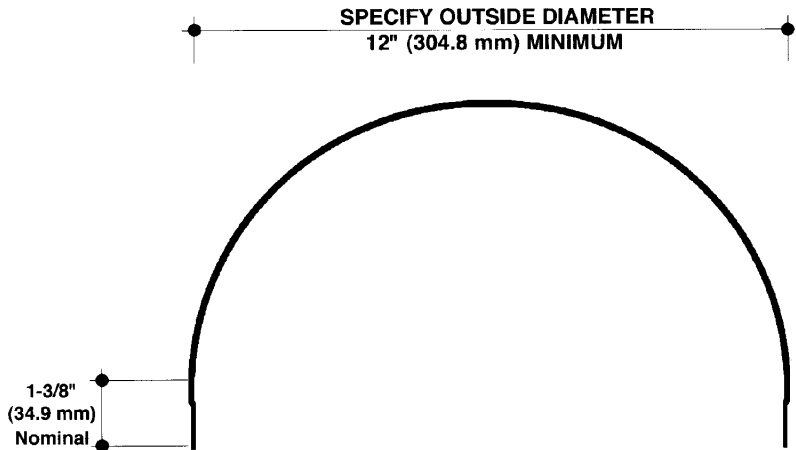

1-3/8"
(34.9 mm)
Nominal

SB-LDT
NO SCALE

CUSTOM BULLNOSE
SECTION

EXAMPLE DETAIL

For use with conventional metal stud construction and 1/2" or 5/8" GPDW.

The SB-LDT is a large diameter bullnose or column cover with two tangential fins for drywall constructions similar to that depicted here. Screws through the installation fins must always engage metal or wood substructure to ensure proper installation.

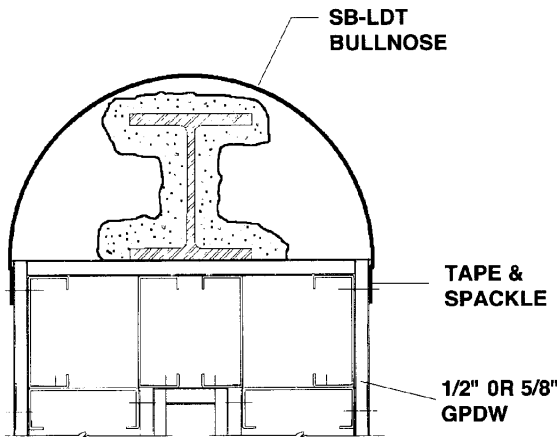

SB-LDT COVER @ PARTITION END
NO SCALE **PLAN/SECTION**

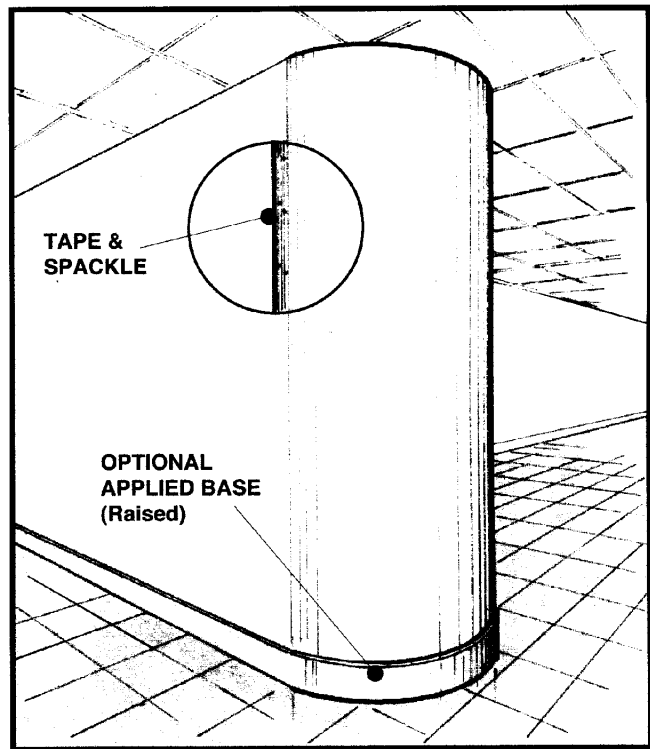

NOTE: REFER ALSO TO SERIES 100 COLUMN COVER BROCHURE

All details, methods and specifications are the exclusive property of Pittcon Softforms® LLC. Pittcon reserves the right to change any specifications or details without prior notification. All Softforms® profiles are available in standard 10' lengths ±1/8" (2.048 M). Other lengths are available as special order items. For custom shapes, sizes, or for special finishes, please contact the factory or your nearest Pittcon sales representative.

Softforms®

PREFORMED ARCHITECTURAL PROFILES
FOR DRYWALL CONSTRUCTION

SB-LDPT

CUSTOM BULLNOSE

SAMPLE SPECIFICATION

specify as: SOFTFORMS® Model # SB-LDPT

Pitcon SOFTFORMS® LLC

6409 Rhode Island Avenue	3330 W. Flower Street
Riverdale, MD 20737	Phoenix, AZ 85017
(800) 637-7638	(800) 637-7638
(301) 927-1000	(602) 233-9100
Fax: (301) 699-8690	Fax: (602) 233-9400

The formed aluminum profile shall incorporate a continuous integral fin for surface contact to conventionally installed gypsum drywall. The swedged fins shall be 1-3/8" wide nominally, with a raised shoulder for taping and spackling to. The formed profile shall be primed with a corrosion-resistant primer compatible with materials normally in use in conjunction with commercial interiors, i.e.: joint compound, latex and enamel paints, and wall covering adhesives. Screws through the installation fins must always engage wood or metal substructure in order to ensure proper installation.

MATERIAL: Aluminum alloy.....3003 H-14 or equal
 Finish.....Factory primed
 Thickness......090" Typical

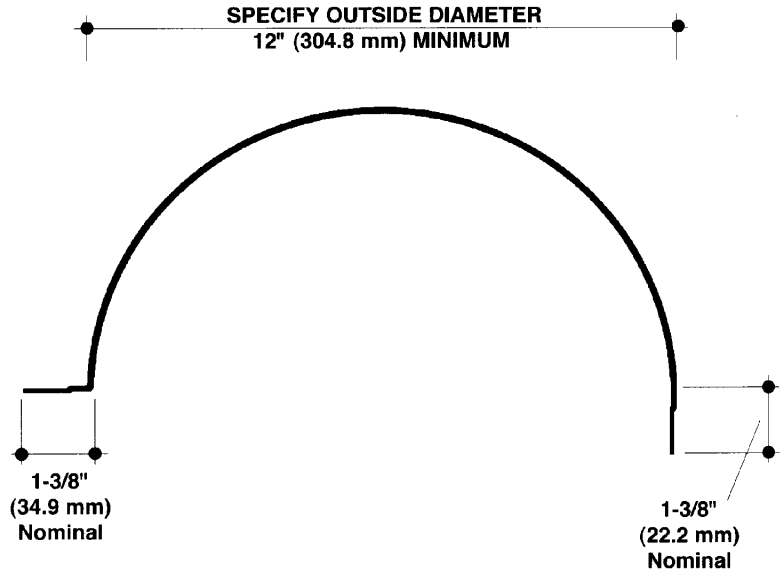

SB-LDPT
NO SCALE

CUSTOM BULLNOSE
SECTION

EXAMPLE DETAIL

For use with conventional metal stud construction and 1/2" or 5/8" GPDW.

The SB-LDPT is a large diameter bullnose or column cover with one tangential fin and one perpendicular for drywall constructions similar to that depicted here. Screws through the installation fins must always engage metal or wood substructure to ensure proper installation.

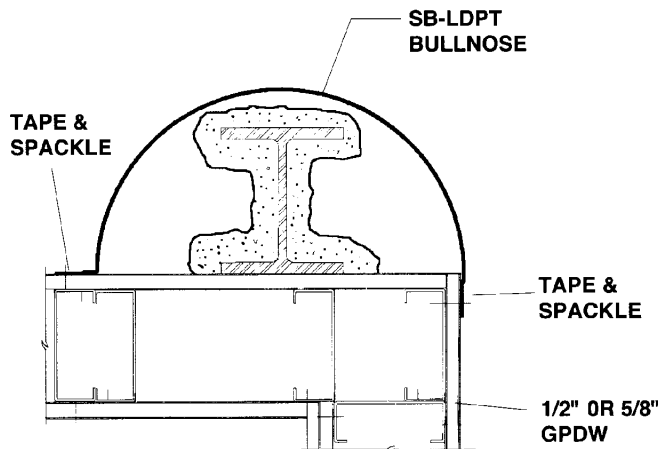

SB-LDPT COLUMN COVER @ STUD WALL
NO SCALE PLAN/SECTION

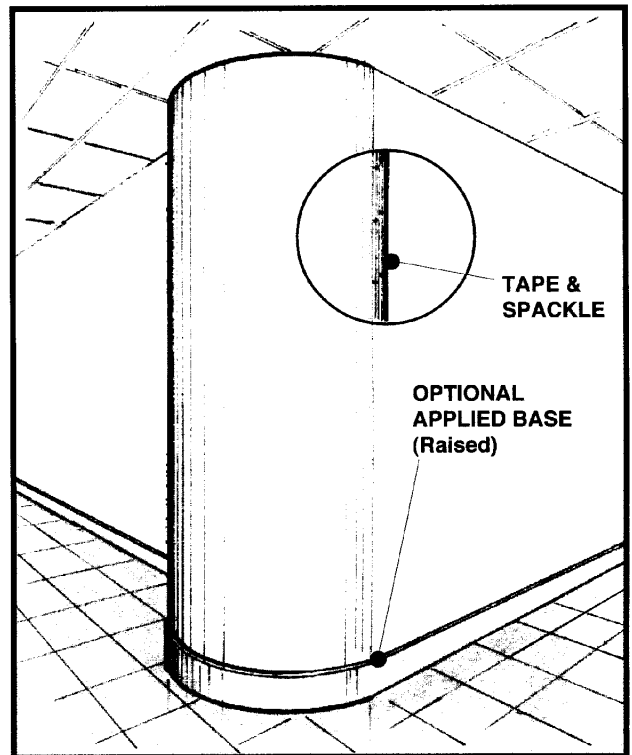

NOTE: REFER ALSO TO SERIES 100 COLUMN COVER BROCHURE

All details, methods and specifications are the exclusive property of Pitcon Softforms® LLC. Pitcon reserves the right to change any specifications or details without prior notification. All Softforms® profiles are available in standard 10' lengths ±1/8" (2.048 M). Other lengths are available as special order items. For custom shapes, sizes, or for special finishes, please contact the factory or your nearest Pitcon sales representative.



www.dcs-sales.com

8805 Tamiami Trail North, Suite 107
Naples, FL 34108

Florida
Thomas Schreiber
Sales Representative

tom@dcs-sales.com

(407) 648-5348 Phone

(407) 505-4336 Fax

Puerto Rico, US Virgin Islands - Caribbean
Island groups-Lucayan Archipelago
Greater Antilles, Lesser Antilles, Bahamas