

Pittcon Industries

DIVISION OF PITTCOON ARCHITECTURAL METALS, LLC

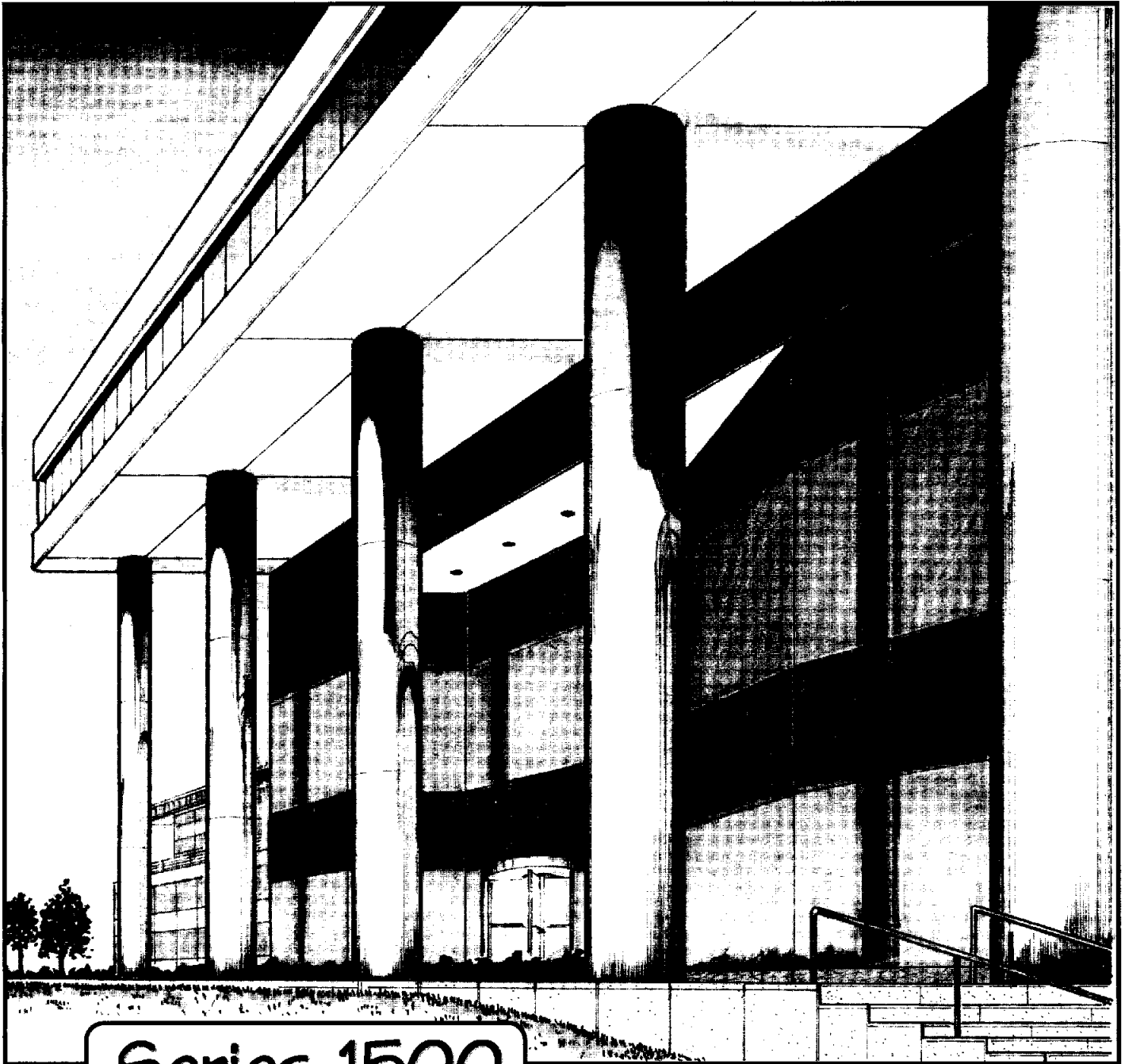

Series 1500

Column Covers

CC-1

Series 1500-Details

Quarter Round Column Cover (Wall Mount)

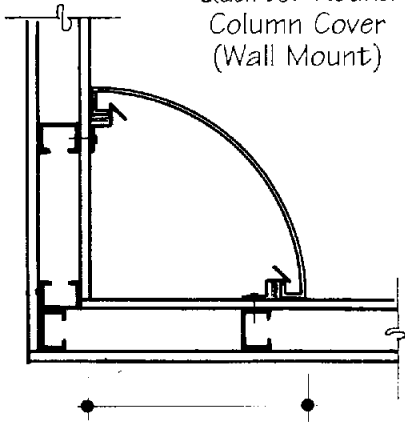

Minimum 6" R (152.4 mm) < 12' tall
 Minimum 8" R (203.2 mm) > 12' tall
 Maximum 36" R (914.4 mm)

Half Round Column Cover (Wall Mount)

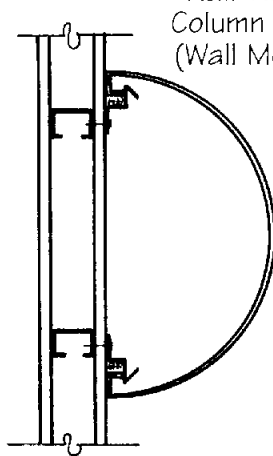

Maximum 18"
 36" Dia (1.397 M)

Three Quarter & Partial Column Covers

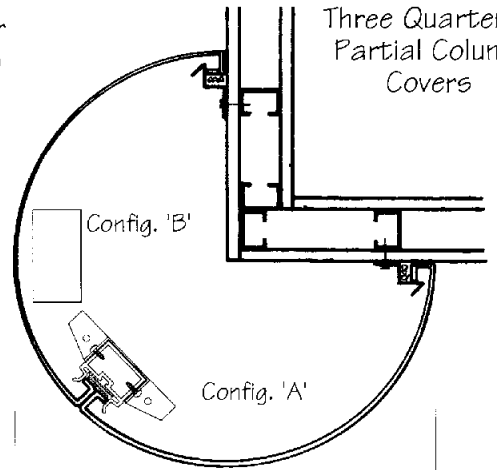

Maximum 48" Dia (1.219 M) Config. 'A'
 Maximum 36" Dia (914.4 mm) Config. 'B'

Full Column Cover

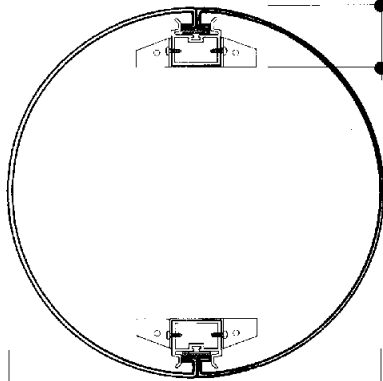

Minimum 12" Dia (304.8 mm) < 12' tall
 Minimum 16" Dia (406.4 mm) > 12' tall
 Maximum 36" (914.4 mm) Dia

2-5/8"
 (66.7 mm)
 Typ

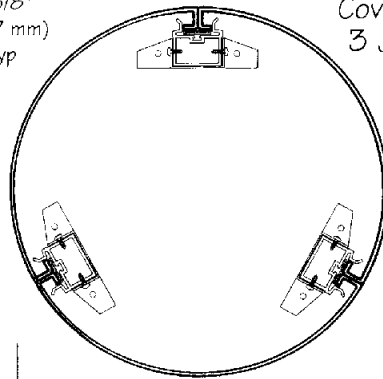

Maximum 55" Dia (1.397 M)

Full Column Cover with 3 Joints

Elliptical Column Cover

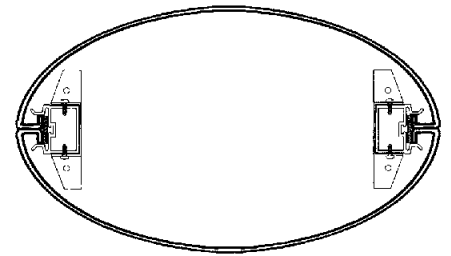

Consult Factory

Race-Track Oval Column Cover



Maximum 90" Dia (2.286 M)
 Available Wider with Addition of Flat Panels

Backing Material to Control Oil-Canning

Extended Half Column Cover

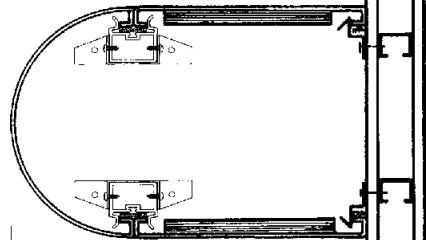

Maximum 72" Width (1.829 M)
 Wider w/Additional Flat Panels

Square, Rectangular, or Octagonal Column Cover

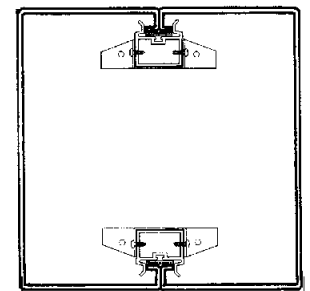

Consult Factory

Note:

Minimum Diameter of Column Covers is Dependant upon Type of Material used (Aluminum, Stainless Steel, etc.) Some Configurations may Require a 14" Minimum Diameter up to 12', and 18" Diameter Above. For More Information, Consult Factory.

Series 1500-Options

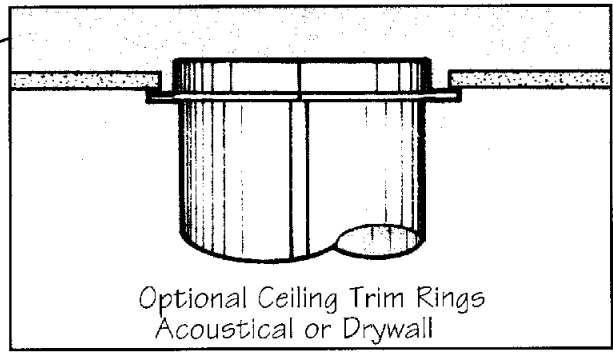
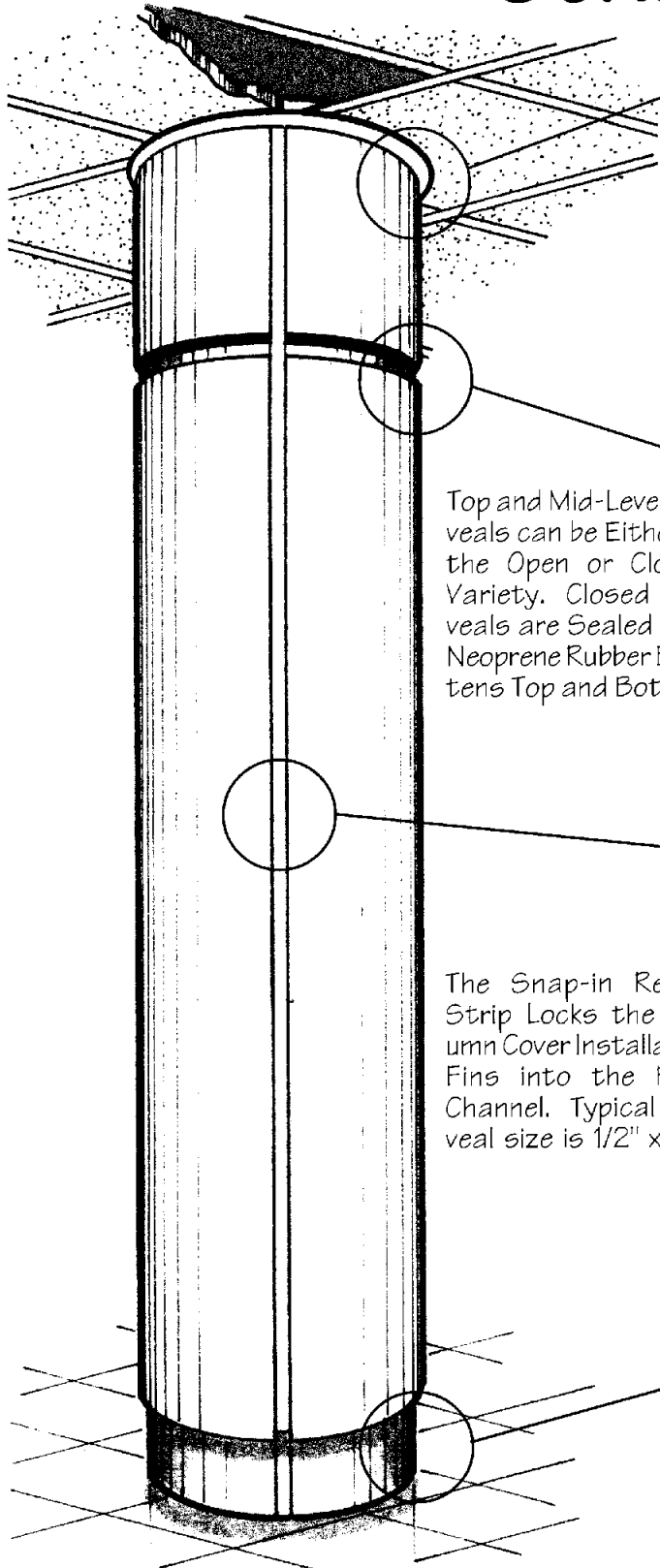

Optional Ceiling Trim Rings
Acoustical or Drywall

Top and Mid-Level Reveals can be Either of the Open or Closed Variety. Closed Reveals are Sealed with Neoprene Rubber Battens Top and Bottom

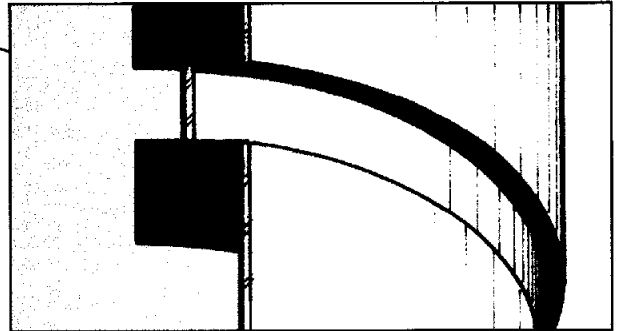

The Snap-in Reveal Strip Locks the Column Cover Installation Fins into the Post Channel. Typical Reveal size is 1/2" x 1/2"

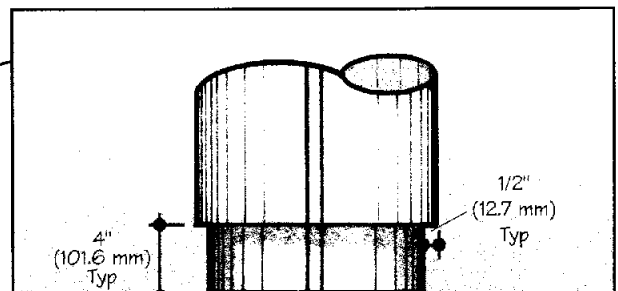
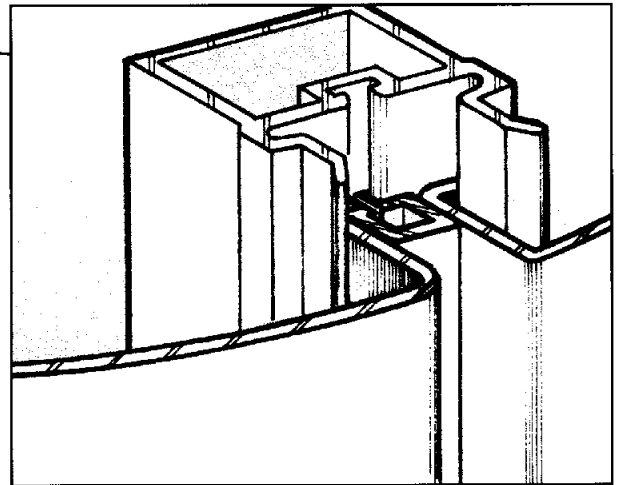

Optional Base or Top Reveals are Available in the Same Material as the Column Cover or in a Contrasting Finish.

The SERIES 1500 SIDE-LOCK™ Column Cover Comes with a Recessed Reveal Joint for Applications Where a Decorative Vertical Reveal is Desired. It can be Designed with a Large Variety of Optional Details.

Series 1500-Options

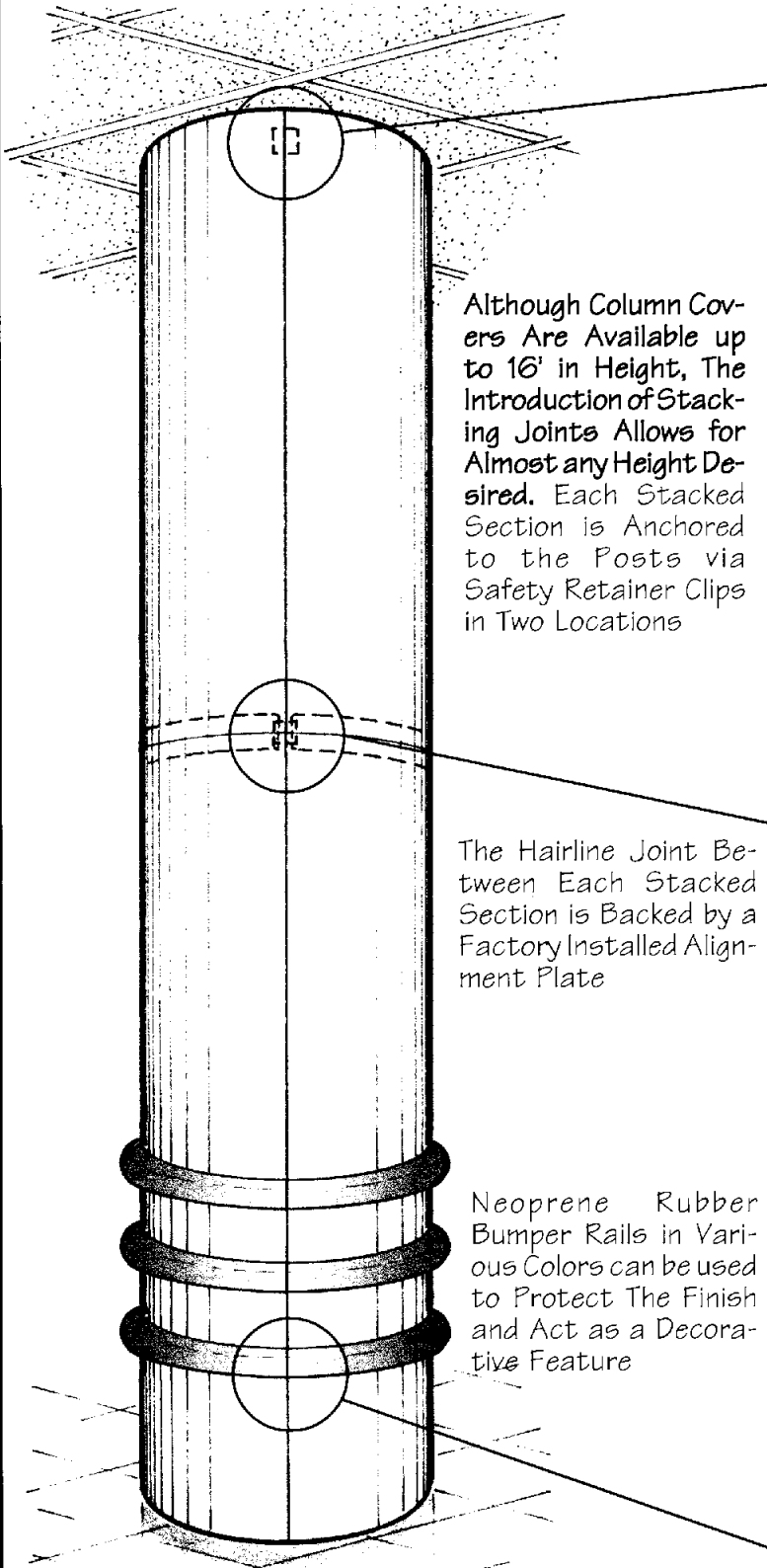

Although Column Covers Are Available up to 16' in Height, The Introduction of Stacking Joints Allows for Almost any Height Desired. Each Stacked Section is Anchored to the Posts via Safety Retainer Clips in Two Locations

The Hairline Joint Between Each Stacked Section is Backed by a Factory Installed Alignment Plate

Neoprene Rubber Bumper Rails in Various Colors can be used to Protect The Finish and Act as a Decorative Feature

The SERIES 1500 SNAP-FORM® Column Cover Comes with a Soft 'V' Joint for Those Applications Where a Vertical Reveal is not Desired. Column Covers Are Available up to 16' in Height in Single Lengths. Stacking Joints Allow for Almost Unlimited Height.

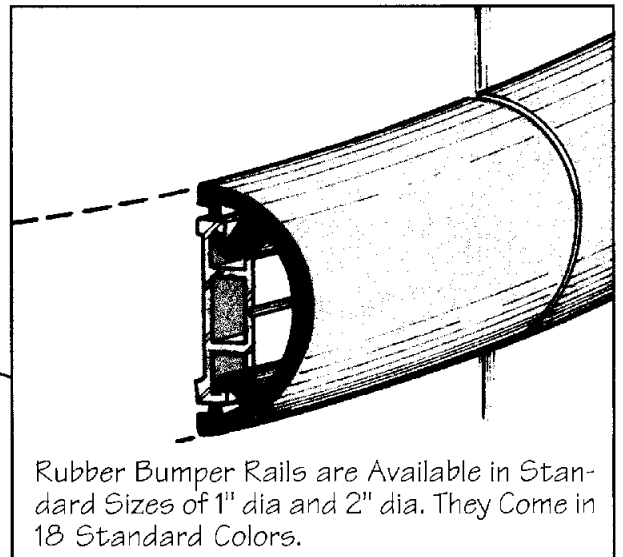
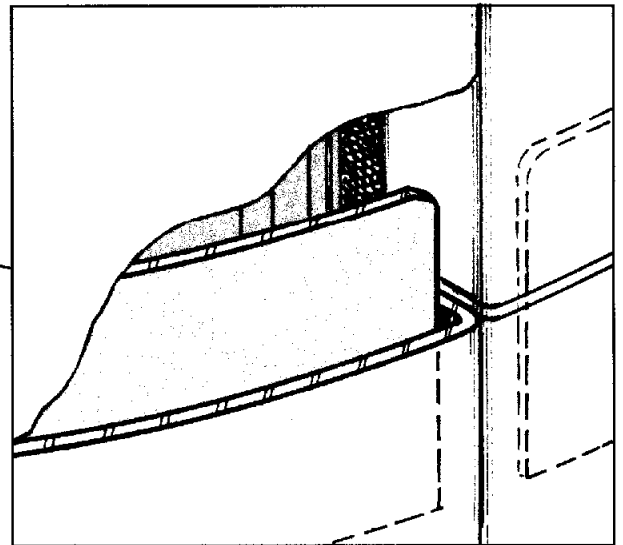
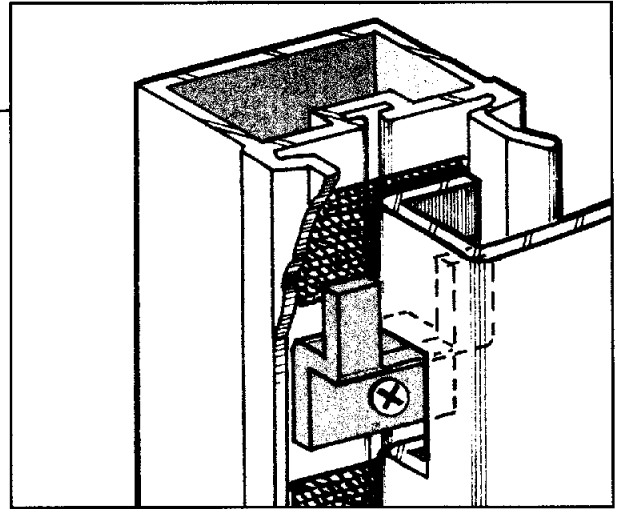

Rubber Bumper Rails are Available in Standard Sizes of 1" dia and 2" dia. They Come in 18 Standard Colors.

Series 1500-Options

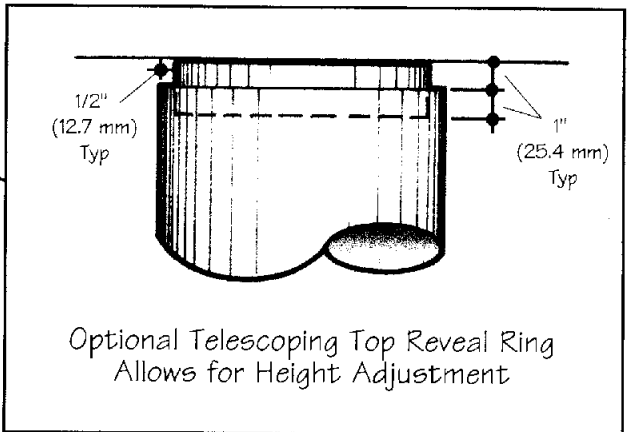
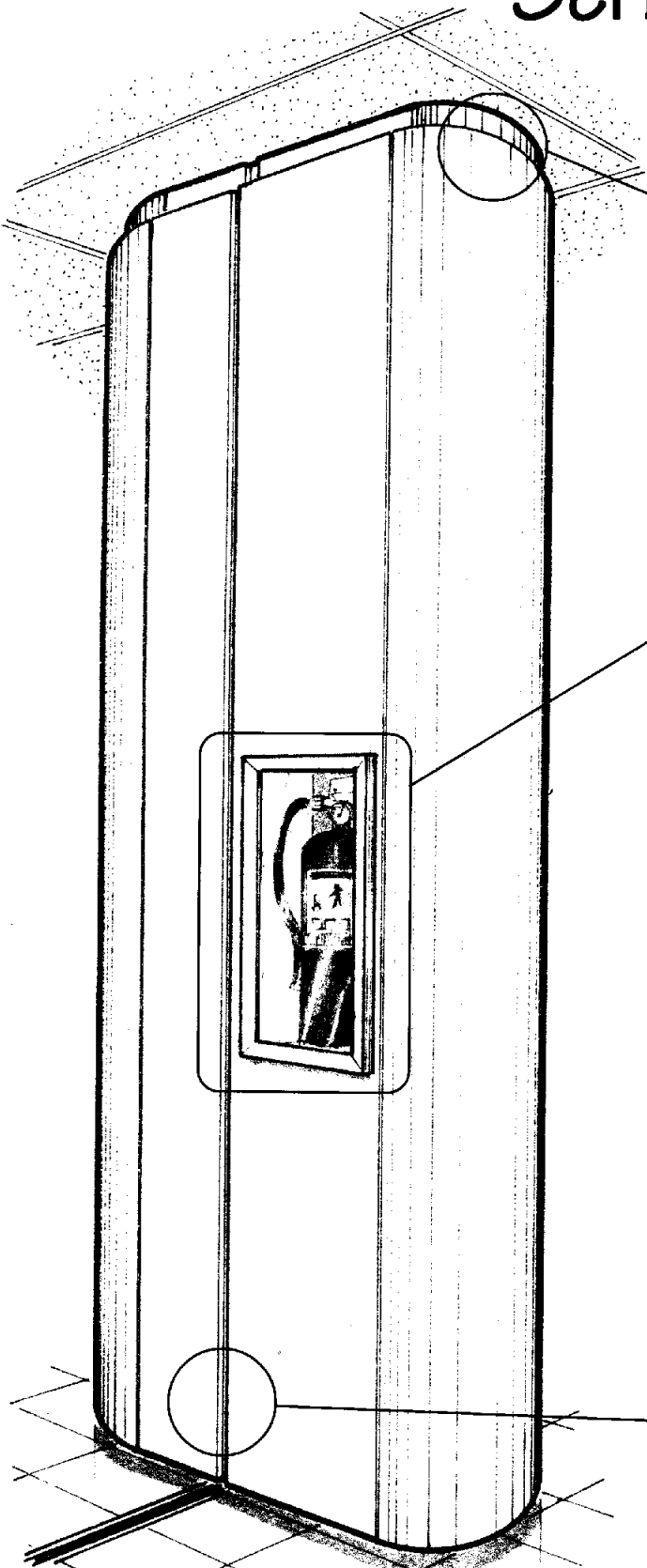

Optional Telescoping Top Reveal Ring
Allows for Height Adjustment

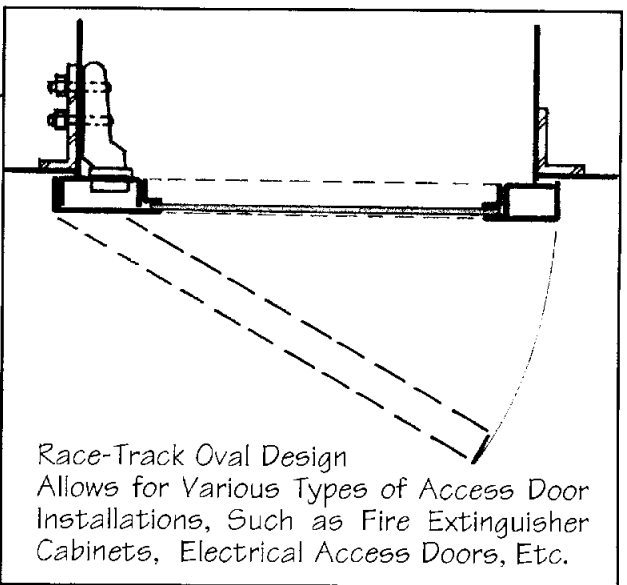

Race-Track Oval Design
Allows for Various Types of Access Door
Installations, Such as Fire Extinguisher
Cabinets, Electrical Access Doors, Etc.

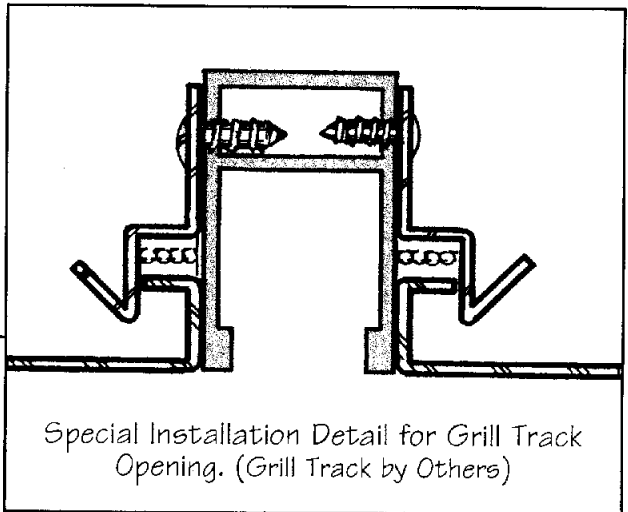

Special Installation Detail for Grill Track
Opening. (Grill Track by Others)

Race-Track Oval Column Covers can be Designed to Accommodate Various Special Field Conditions Such as Those Shown Here. It is Perfect for Those Conditions Where Concealing HVAC or Electrical Services is Required.

These Options, as well as Most Others, are Available with all of Our Column Cover Designs. Please Consult with the Factory for Your Particular Design Needs.

Series 1500-Options

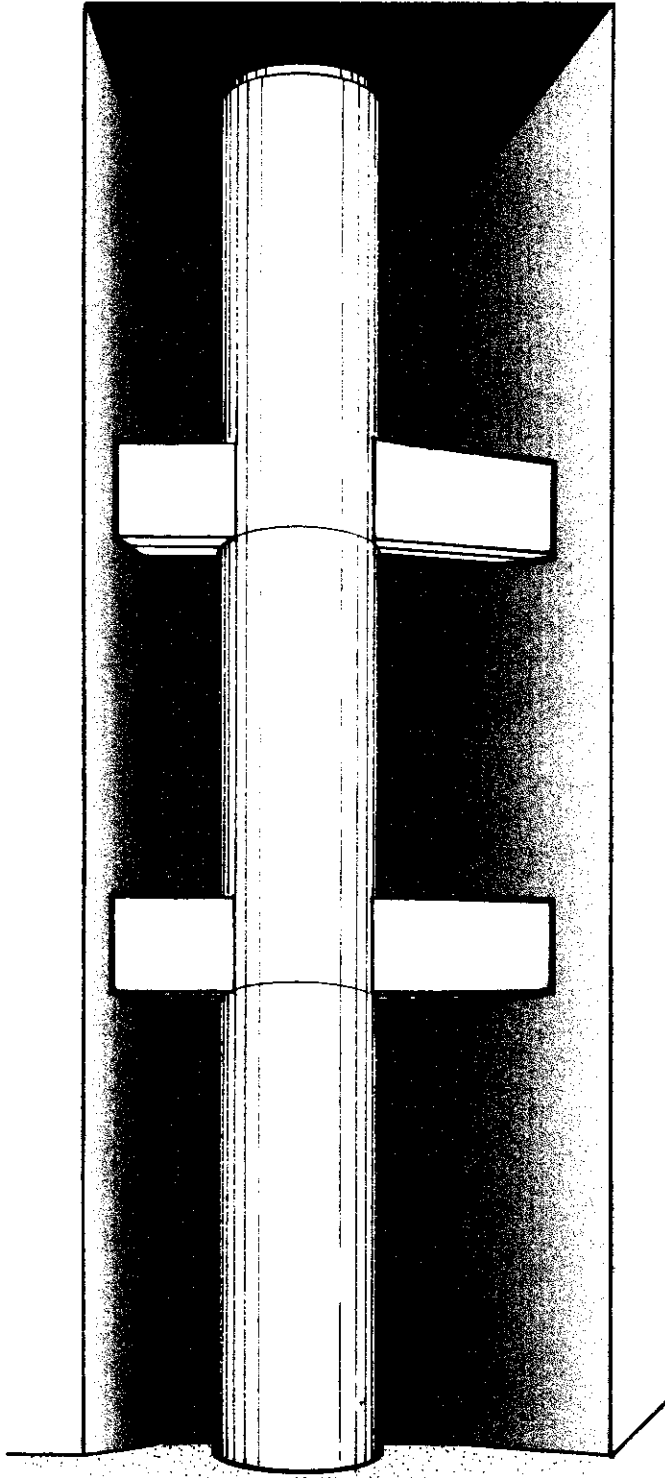

Column Covers can be Combined with Beam Covers to Completely Enclose all Existing Structural Members. Joints can be Configured in Different Manners to Allow for Alignment and Decorative Considerations.

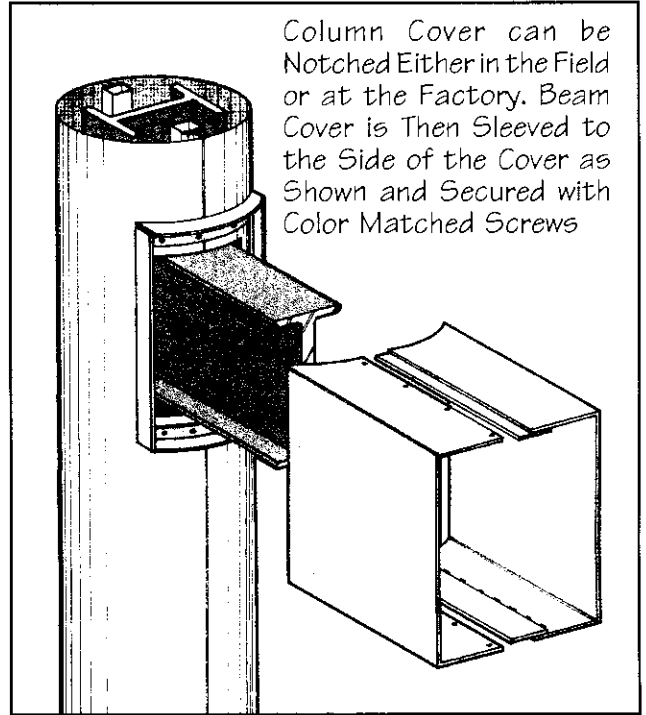

Column Cover can be Notched Either in the Field or at the Factory. Beam Cover is Then Sleeved to the Side of the Cover and Secured with Color Matched Screws

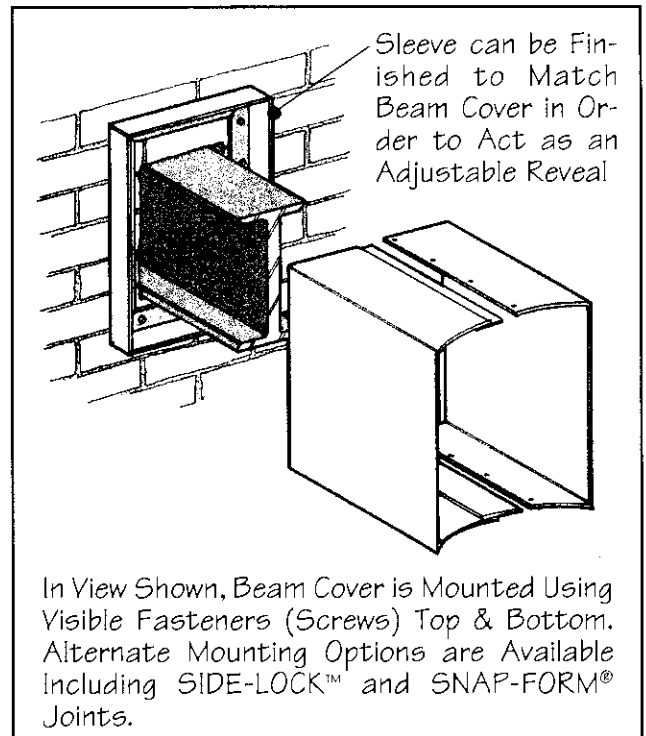

Sleeve can be Finished to Match Beam Cover in Order to Act as an Adjustable Reveal

In View Shown, Beam Cover is Mounted Using Visible Fasteners (Screws) Top & Bottom. Alternate Mounting Options are Available Including SIDE-LOCK™ and SNAP-FORM® Joints.

These Options, as well as Most Others, are Available with all of Our Column Cover Designs. Please Consult with the Factory for Your Particular Design Needs.

Series 1500-Finishes

Column Covers are Available in the Following Material and Finishes:

Aluminum in .090" Standard Thickness (2.3 mm)

- *Pattern Metal* finish with Clear or Semi-transparent Clear-coat (see *Pattern Metal* brochure for details)
- Painted in PPG Coraflox® fluoropolymer finish
- Painted in a hi-gloss polyurethane finish
- Clear satin anodized finish
- Light, medium, or dark bronze, or black anodized finish
- Clad with matte or hi-gloss plastic laminate finishes
- Clad with Belbien® vinyl laminate finishes
- Clad with wood veneers (unfinished)
- Primed finish for field painting

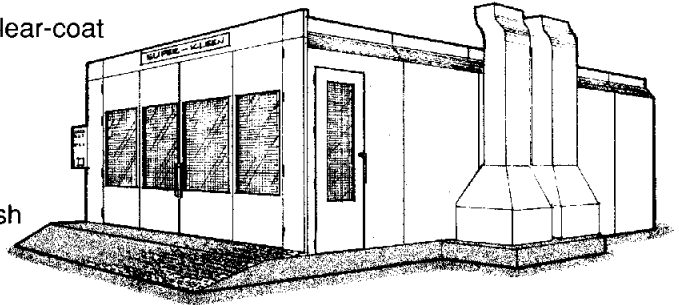

Our state of the art finishing booth with down-draft air filtration system assures maximum dust and temperature control.

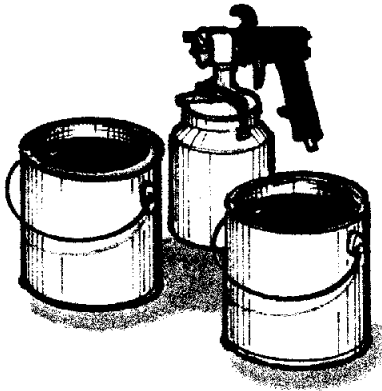

Stainless Steel in 16ga -14ga thickness (1.6 mm-1.9 mm)

- *Pattern Metal* finish (see *Pattern Metal* brochure for details)
- #4 brushed finish
- #8 polished finish
- Rigid-Tex® Textured finishes
- Prismatic® colored finishes

Muntz Brass in 14ga -12ga thickness (1.5 mm-2 mm)

(Factory clearcoat available for an additional charge.)

- #4 brushed finish
- #8 polished finish

Pittcon specializes in all types of the highest quality architectural paint finishes, including fluoropolymer, acrylic polyurethane enamel, acrylic lacquer, etc.

Other materials and thicknesses are available as options, at an additional cost. Factory primed or mill finish available for immediate delivery. Finishes meet or exceed AAMA standards for scratches or blemishes.

Coraflox® is a registered trademark of PPG Industries.
Rigid-Tex® is a registered trademark of Rigidized Metals Corp.
Prismatic® is a registered trademark of B & M Finishers, Inc.
Belbien® is a registered trademark of the C.I. Kasei Company, LTD of Japan.

Series 1500-Details

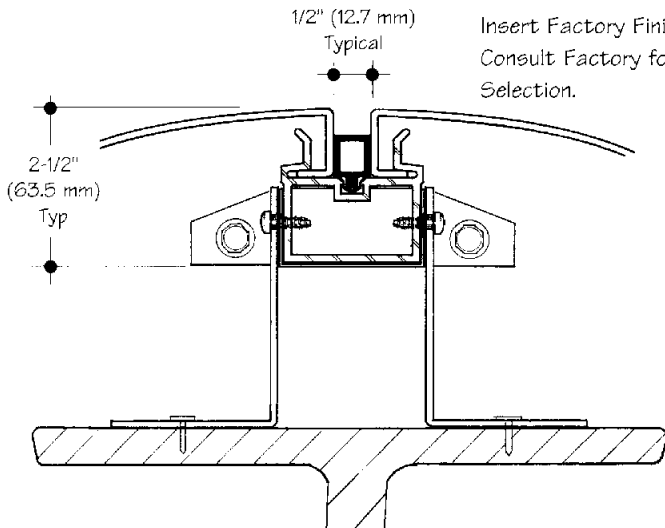

SIDELOCK™ Reveal Joint

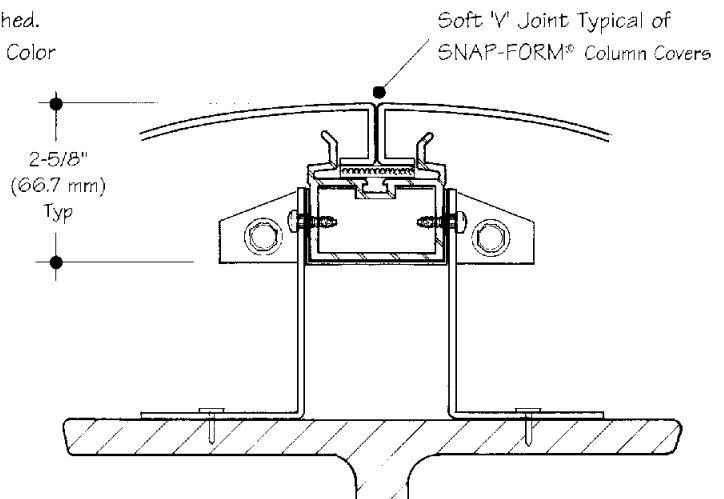

SNAP-FORM® Soft "V" Joint 7

Series 1500-Installation

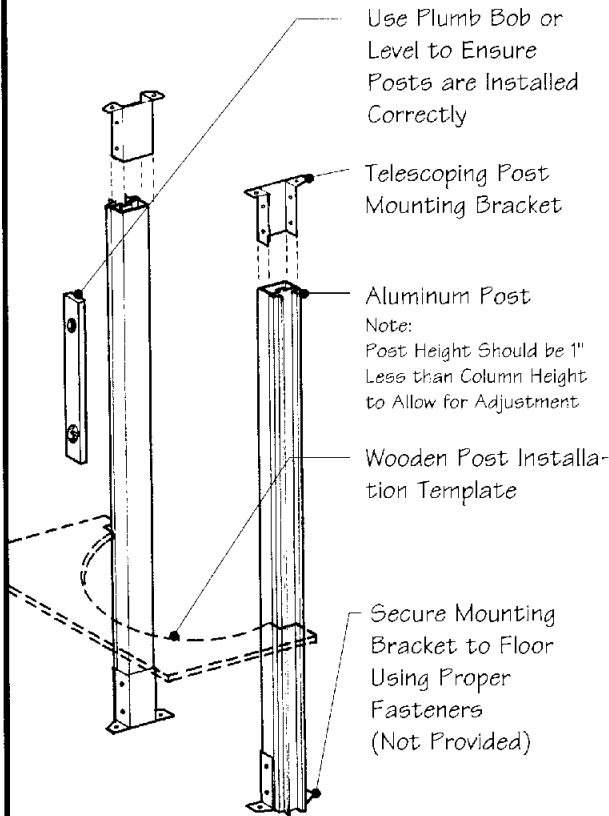

Installation Details

No Scale

Use Plumb Bob or Level to Ensure Posts are Installed Correctly

Telescoping Post Mounting Bracket

Aluminum Post
Note:
Post Height Should be 1" Less than Column Height to Allow for Adjustment

Wooden Post Installation Template

Secure Mounting Bracket to Floor Using Proper Fasteners (Not Provided)

The SERIES 1500 column cover system consists of the following parts:

- 1) Two custom rolled column cover half sections
- 2) Four post mounting brackets with mounting screws
- 3) Two extruded aluminum posts (with reveal inserts if SIDE-LOCK™)
- 4) Mid-level post reinforcement brackets
- 5) Self tapping flat head screws for bracket attachment
- 6) Post installation template for aligning posts
- 7) One set of drawings / instructions / suction cup per order

The following customer supplied items are also recommended:

- 1) Plumb bob & carpenter's level
- 2) Ramset or lag type masonry fasteners for mounting brackets

Typical Installation Procedure

- 1) Determine the position of the column cover around structural member. Install one stud in place, using a level to ensure plumb-ness. Position the opposite stud in place using the supplied post installation template. Make sure that studs are securely fastened to the ceiling and floor utilizing proper fasteners. Install any base reveals at this time fastening to both post and floor.
- 2) Seat one side of first column half into the opening of the metal post. Using the suction cup, spring column half gently around outside of opposite post and seat in opening. Repeat this procedure for the other column half, taking care not to unduly stretch halves.
- 3) If column cover is a SNAP-FORM® model, use a heavily padded 2x4 and rubber mallet to engage the two sides. Starting at the bottom of the column cover and working your way up, firmly strike the padded block with the rubber hammer on both column halves along joint. This will positively engage the interlock assembly. If your column is a SIDE-LOCK model, insert the vertical locking reveal between the two column halves and engage it in the post. This is accomplished by using a heavily padded board (7/16" or less in width) to strike the insert with, starting at the bottom and working your way upwards. Install any top reveals last, making sure that they are properly supported to ceiling and post.
- 4) Remove the protective covering from the column cover halves and clean as per attached directions. Your column cover is now complete.

SAMPLE SPECIFICATION

Section 05-58-13 Architectural Metal Column Covers

Part 1 - General

1.01 Description of work

A. Furnish all material necessary for a complete installation of the SERIES 1500 column covers. Column covers to be self-aligning, positive interlock, without exposed fasteners or supports.

1.02 Submittals

A. Submit complete shop drawings detailing quantities, sizes, finish, configurations, and column attachment methods.
B. Submit product literature, specifications, information, and installation instructions.

1.03 Quality Assurance

A. Manufacturer to have a minimum of ten years experience in the manufacturing of column covers.
B. Manufacturer to inspect all aspects of the product to ensure that specifications have been met, and that they comply with approved shop drawings.
C. Manufacturer shall issue a one year limited warranty ensuring product against defects in workmanship and materials.

Part 2 - Products

2.01 Acceptable Manufacturers

Pittcon Industries
6409 Rhode Island Ave.
Riverdale, MD 20737

Pittcon Industries
3330 W. Flower Street
Phoenix, Arizona 85017

2.02 Materials

A. Column covers shall be roll-formed from (*Specified Material*) with (*Specified Finish*) to match architect's sample.
B. All fasteners are to be concealed.
C. All support structures to be supplied by column cover manufacturer.
D. All column covers are to be shipped with protective material on all exposed surfaces.

2.03 Fabrication

A. Column covers shall be roll-formed to specific dimensions and tolerances, and accurately formed to radii shown on drawings.
B. Column covers shall be fabricated in two vertically divided sections attached with a demountable interlock joint.
C. Column covers shall be fabricated in single length heights of 16' where required, with the addition of stacking joints to allow for heights above 16'.

Part 3 - Execution

3.01 Inspection & Installation

A. Contractor to inspect column covers upon receipt to ensure that no damage has occurred during shipment.
B. Column cover to be correctly oriented and installed in accordance with manufacturer's shop drawings and installation instructions to ensure proper installation.
C. Column cover to be erected plumb and level.

3.02 Cleaning & Protection

A. Contractor to remove protective material supplied by column cover manufacturer.
B. Contractor to clean all visible surfaces after installation.
C. Contractor to protect column covers from damage by other trades

Pittcon Industries Division Pittcon Architectural Metals, LLC

6409 Rhode Island Avenue
Riverdale, Maryland 20737
(800) 637-7638, (301) 927-1000
Fax: (301) 699-8690

3330 W. Flower Street
Phoenix, Arizona 85017
(800) 637-7638, (602) 233-9100
Fax: (602) 233-9400

Series 1500 Column Cover Specifications

Section 05-58-13 Architectural Metal Column Covers

Job Name:

SPECIFICATION

Part 1 - General

1.01 Description of work

A. Furnish all material necessary for a complete installation of the SERIES 1500 column covers. Column covers to be self-aligning, positive interlock, without exposed fasteners or supports.

1.02 Submittals

- A. Submit complete shop drawings detailing quantities, sizes, finish, configurations, and column attachment methods.
B. Submit product literature, specifications, information, and installation instructions.

1.03 Quality Assurance

- A. Manufacturer to have a minimum of ten years experience in the manufacturing of column covers.
B. Manufacturer to inspect all aspects of the product to ensure that specifications have been met, and that they comply with approved shop drawings.
C. Manufacturer shall issue a one year limited warranty ensuring product against defects in workmanship and materials.

Part 2 - Products

2.01 Acceptable Manufacturers:

Pittcon Industries

6409 Rhode Island Ave.
Riverdale, MD 20737

Pittcon Industries

3330 W. Flower Street
Phoenix, Arizona 85017

2.02 Materials

- A. Column covers shall be roll-formed from (*Specified Material*) with (*Specified Finish*) to match architects sample.
B. All fasteners are to be concealed.
C. All support structures to be supplied by column cover manufacturer.
D. All column covers are to be shipped with protective material on all exposed surfaces.

2.03 Fabrication

- A. Column covers shall be roll-formed to specific dimensions and tolerances, and accurately formed to radii shown on drawings.
B. Column covers shall be fabricated in two vertically divided sections attached with a demountable interlock joint.
C. Column covers shall be fabricated in single length heights of 16' where required, with the addition of stacking joints to allow for heights above 16'.

Part 3 - Execution

3.01 Inspection & Installation

- A. Contractor to inspect column covers upon receipt to ensure that no damage has occurred during shipment.
B. Column cover to be correctly oriented and installed in accordance with manufacturer's shop drawings and installation instructions to ensure proper installation.
C. Column cover to be erected plumb and level.

3.02 Cleaning & Protection

- A. Contractor to remove protective material supplied by column cover manufacturer.
B. Contractor to clean all visible surfaces after installation.
C. Contractor to protect column covers from damage by other trades.

Pittcon Industries Division Pittcon Architectural Metals, LLC

6409 Rhode Island Avenue
Riverdale, Maryland 20737
(800) 637-7638 , (301) 927-1000
Fax: (301) 699-8690

3330 W. Flower Street
Phoenix, Arizona 85017
(800) 637-7638 , (602) 233-9100
Fax: (602) 233-9400

© 2008 Pittcon Industries

Fabricated with Pride in



Riverdale, Maryland-U.S.A.

CC-10



COLUMN COVERS

Following is the complete listing of the Pittcon Column Cover systems. From the SERIES 9000 Ceramicsteel clad column cover, to the SERIES ECC economy column covers, we have a system that will fit every budget and every condition. Our column covers come in a wide variety of finishes, colors and materials, giving the architect or interior designer complete freedom of choice. Please contact us if you have a situation which requires a customized solution.

All material and designs in this binder are the exclusive property of Pittcon Industries.

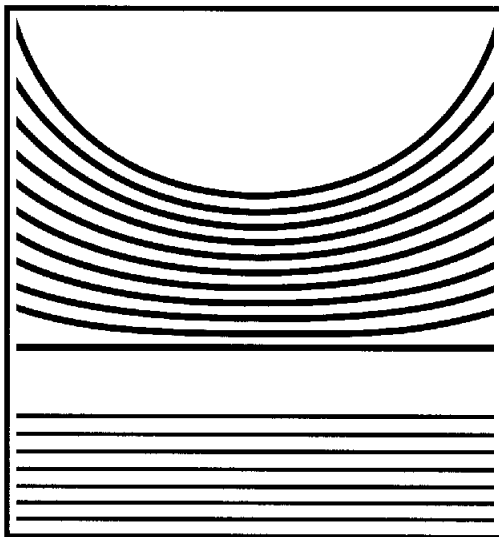

**Pittcon
Industries**

DIVISION OF PITTCON ARCHITECTURAL METALS, LLC

Florida Representative:

DCS Architectural Products

850-319-0381 North Florida

239-298-6150 SW Florida

e-mail: sales@dc-sales.com

407-648-5348 Central Florida

954-938-0085 SE Florida

www.dcsarchitectural.com

† Mouse Click on any page during the specific product
display view will return to that Product Index



All Products are American Made
Fabricated, Manufactured, and Finished
in the United States of America

LEED® Architectural Green Building commitment